



OPERATING MANUAL

Bidop ES-100V3

OPERATING MANUAL

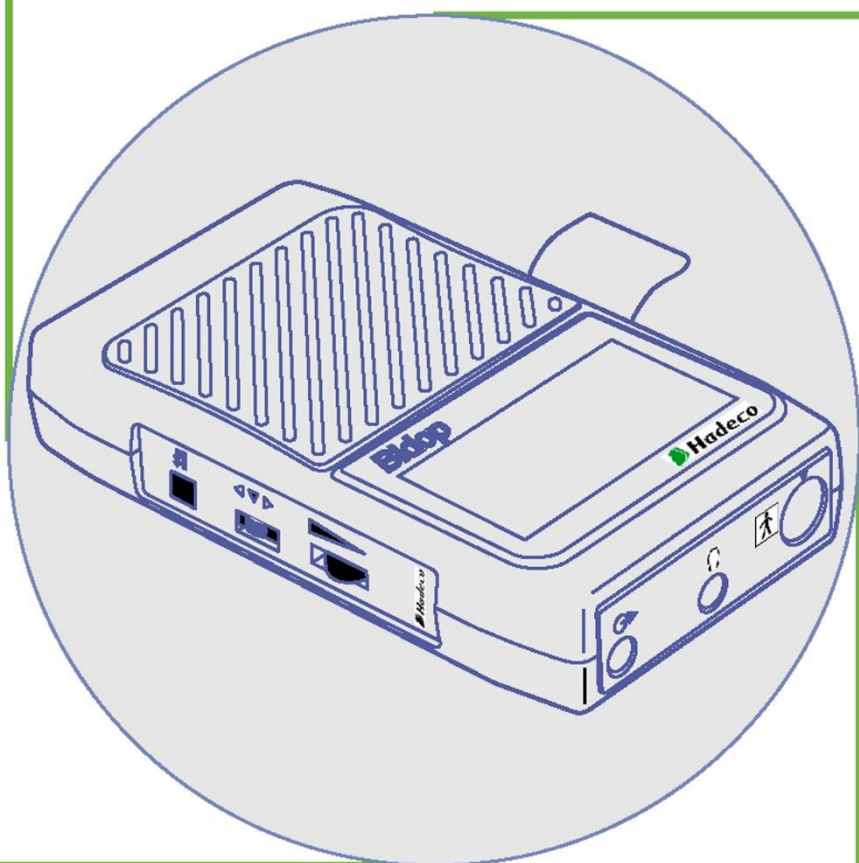

TABLE OF CONTENTS

Cautions

1. Introduction	1
1-1. Features	2
1-2. Clinical applications.....	3
2. Appearance.....	4
2-1. Front view.....	4
2-2. Back side view and Probe	5
3. Quick start.....	6
3-1. Turning the unit ON / OFF	6
3-2. Checking battery level and replacing battery.	7
3-3. Measuring blood velocity	8
3-3-1.Normal mode.....	8
3-3-2.Site guidance mode.....	10
3-4. Measuring heart rate (2MHz only)	12
3-5. 2 MHz BEEP mode	14
4. Menu and Mode settings.....	15
4-1. Menu	15
4-1-1. Menu operation	15
4-1-2. MENU for Blood Velocity Measurement mode	16
4-1-3. MENU for Blood Velocity Freeze mode	16
4-1-4. MENU for Heart Rate mode (Measurement and Freeze)	17
4-1-5. MENU for 2MHz BEEP Measurement mode	18
4-1-6. MENU for 2MHz BEEP Freeze mode.....	18
4-2. Mode setting details	19
a. MEMORY - STORE	19
b. MEMORY - READ.....	19
c. MEMORY - CLEAR.....	20
d. MODE (Baseline mode).....	20
e. DIR (Flow direction)	20
f. TIME (Time scale).....	21
g. DISP (DISP, OTHERS – DISP, DISP/BEEP)	21
h. SOUND (Beep sound for HR)	21
i. UPPER (Upper limit for HR).....	21
j. LOWER (Lower limit for HR)	21
k. LIMIT-1 (Limit for 2MHz BEEP mode).....	22
l. LIMIT-2 (Maximum / Average for 2MHz BEEP mode).....	22
m. OTHERS - LANGUAGE.....	22

n. OTHERS - UNIT (cm/s / kHz)	22
o. OTHERS - FILTER (Arterial / Venous filter)	22
p. OTHERS - SMOOTH (Smoothing filter).....	22
q. OTHERS - CAL (Calibration)	23
r. OTHERS - BACKLIGHT	23
s. OTHERS - AUTO-OFF (Automatic shut-off).....	23
t. OTHERS - FREEZE	23
u. OTHERS - PRB20MHz.....	23
v. FLOW (Blood volume flow) / w. DIAMETER (Estimated vessel diameter)	24
5. Maintenance	25
5-1. Performance check by user.....	25
5-2. Cleaning	25
5-3. Probe sterilization.....	25
5-3-1. Sterilizable probes (Amplifier required)	25
5-3-2. Sterilization.....	26
5-4. Warranty.....	29
6. Supplemental information	30
6-1. Basic mode	30
6-2. LCD display	30
6-2-1. Blood Velocity mode	30
6-2-2. Heart Rate mode (Only 2 MHz probe).....	32
6-2-3. 2 MHz BEEP mode	34
6-3. Numerical data	35
6-4. External outputs	36
6-5. Symbol list.....	36
6-6. Contents in package.....	36
7. Options	37
7-1. Probe selection.....	37
7-2. Others	38
7-3. Photoplethysmograph	39
7-4. Foot Temperature (Except European Union Countries).....	44
8. Technical information	46
8-1. Principles.....	46
8-2. Block diagram.....	46
8-3. Specifications	46
8-4. Safety standards	48

Cautions

Please read the following important points carefully before you operate the unit.

1. Only skilled persons should operate the unit.
2. Use the unit for measuring blood flow.
3. Do not apply any modification to the unit.
4. Device placement
 - (1) Follow the requirements for storage and operating environments.
 - (2) Do not place it near water.
 - (3) Do not place it where atmospheric pressure, temperature, humidity, ventilation, sunlight, dust, salt, sulfur and so forth will not affect the unit adversely.
 - (4) Pay attention to the stability conditions such as inclination, vibration, and shock during transportation and installation work.
 - (5) Do not place it where chemicals are stored, or where gas may be generated.
 - (6) Do not place it where the unit tends to fall.
 - (7) Do not place it on or adjacent other electronic device.
5. Before use:
 - (1) Make sure that the unit operates safely and correctly by following the maintenance procedures mentioned in "§ 5-1. Performance check by user".
 - (2) Make sure that all cables are connected correctly and safely.
 - (3) Using it with other equipment together may cause a misdiagnosis or danger to patient due to a malfunction.
 - (4) Double check that all the cables do not obstruct any external connection to the patient.
 - (5) Do not sterilize the main unit, non-sterilizable probes and amplifiers to prevent any damage.
 - (6) Sterilizable probes (optional) should be sterilized before use. (See §5-3. Probe sterilization)
6. Operation
 - (1) Do not use the unit simultaneously with an electric cautery, cardioverter, other ultrasonic device or mobile phone.

- (2) Be careful not to exceed time and volume of diagnosis treatment required.
- (3) Always make sure the unit and patient are not under abnormal conditions.
- (4) When any abnormality is found on the unit or the patient, take proper action such as stopping operating the unit in a manner safe to the patient.
- (5) Do not let the patient touch the unit.
- (6) Use the designated components only such as the probe.
- (7) Do not use the components for other devices.
- (8) Use the unit under the operating environments specified on the specifications.
- (9) Use the Bidop as specified in the Operating manual.
- (10) Do not use the unit in a strong electromagnetic field or it may cause incorrect measurement.

7. After use

- (1) Turn the unit off the way specified.
- (2) Do not pull the cable(s) too much while disconnecting or it may cause damage.
- (3) Clean the unit, cables and probes and place them in right place for the next use.

8. Storage

- (1) Follow the caution (2) to (6) of section # 4 Device placement in the previous page.
- (2) Clean the unit, probes and place them in right place for the next use.
- (3) When using the unit next time, perform the maintenance to make sure it works properly and safety.

9. Maintenance

- (1) Do the periodical maintenance by following the procedures mentioned in "§ 5-1. Performance Check by user".
- (2) The maintenance must be done at least once a year.

10. Probes

- (1) Clean the probe using damp cloth before use. Using alcohol or thinner may damage the probe.
- (2) The probe transducer tip is very thin and delicate. Please handle with great care and use the probe cap when not in use.

- (3) Optional sterilizable probe (reusable & disposable) can be sterilized in the manner described in “§5-3. Probe sterilization”. However, only one time sterilization is possible for disposable probe, and do not reuse it. Except optional ACP probe, do not sterilize probes by steam autoclave.

11. Ultrasonic gel

- (1) Do not apply ultrasonic gel to the probe body other than the tip of probe.
- (2) Using other materials may damage the probe.
- (3) The ultrasonic gel enclosed is non-sterile and do not use it for surgeries.
- (4) Incidence of allergy: Discontinue use of gel if an allergic reaction occurs.

12. Battery

- (1) When battery is extremity low, the LCD display will not operate. Also there will be no speaker sounds. Replace the battery.
- (2) Use a 9 volt alkaline square type battery. A non-alkaline may cause a shortage of power.
- (3) When not using the unit for a long time, remove the battery.

13. Repair services

- (1) When the unit gets out of order, contact the dealer for repair from whom you purchased the unit.
- (2) Only authorized persons should perform the repair services.

14. Do not disassemble the Bidop.

15. Destruction

- (1) In case of destruction of the unit, follow the instructions for disposition of the destruction appointed by each country or local government.
- (2) Do not place battery in fire or it may cause an explosion and injury.

16. Any connected computer is not allowed to be in the patient area according to IEC60601-1.

1. Introduction

Thank you very much for choosing the Bidop ES-100V3.

The Hadecco Bidop ES-100V3 is a uniquely designed bi-directional pocket Doppler with LCD display. It detects arterial and venous blood flows in extremities.

The Bidop displays velocity waveform and numerical data. Please read this manual carefully to acquaint yourself with the Bidop operation.

This medical device can be used by doctor for the purposes mentioned in "§1-2. Clinical Applications" for patient in hospital and clinic.

For the use with computer, please refer to the operating manual for Windows linking software optional.

1-1. Features

- **BI-DIRECTIONAL HAND HELD DOPPLER WITH LCD DISPLAY**
Displays real-time waveforms, numerical data on backlit LCD.
- **Hadeco DESIGNED SMART MICROPROCESSOR**
Various mode settings are available for optimal measurement with the menu displayed on the LCD and unique side Shuttle Button.
30 waveform memories.
- **CONVENIENT PROBE ACTIVATION BUTTON**
Freezes waveform and numerical data for notation.
Turns Bidop ON and OFF.
- **MULTIPROBE SELECTION of 2, 4, 5, 8, 10 and 20 MHz**
- **USB COMPUTER INTERFACE**
Stores waveforms and numerical data in your computer for data analyzing and filing. Communication cable and Smart-V-Link Windows software are optional.
- **PHOTOPLETHYSMOGRAPH (PPG) PROBE OPTIONAL**
Expands arterial & venous testing.

1-2. Clinical applications

- **Detections of arterial and venous blood flow velocity for vascular disease**

Probes to be used:





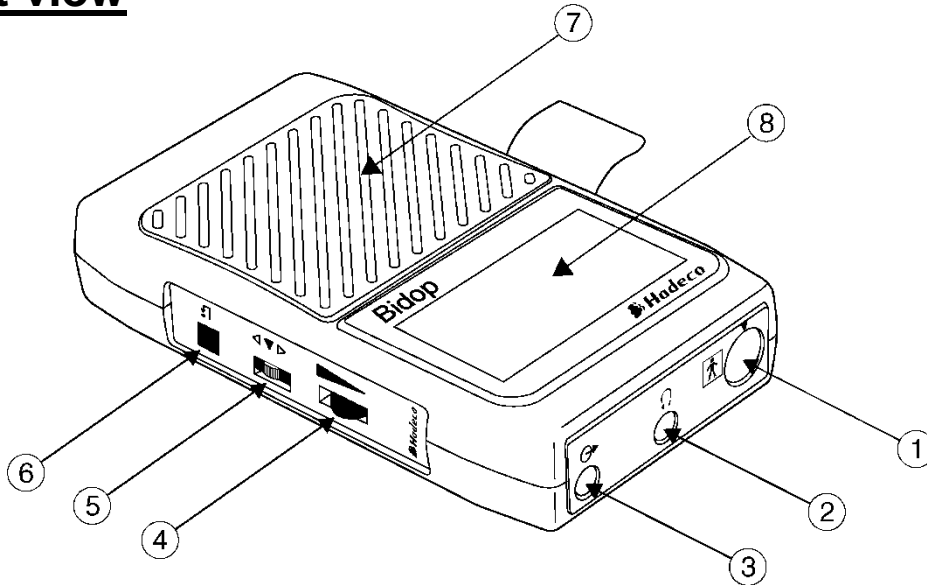

BT2M20S8C	(2 MHz)
BT4M05S8C	(4 MHz)
BT5M05S8C	(5 MHz)
BT8M05S8C	(8 MHz)
BT10M5S8C	(10 MHz)

- * PEAK & MEAN blood velocity determinations
- * Detection of arterial and venous blood flow velocity for vascular disease

2. Appearance

2-1. Front view



- 1. Probe connector: To connect probe.
- 2. Headset:  To connect headset. It cuts off the speaker.
- 3. Serial port:  To connect computer. (USB)
- 4. Volume control:  To adjust sound volume.
- 5. Shuttle Button:  To turn the unit ON/OFF, press it inside.
 To select menu, turn it up or down.
 To set the mode or execute command, press it inside.
 To display next memory data, turn it up and down.

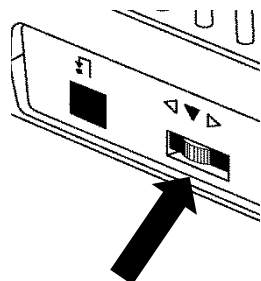

Press inside

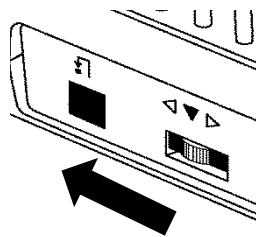

Turn up

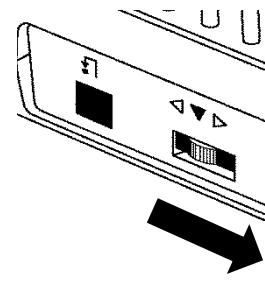

Turn down

6. BACK button:  To quit menu mode.
To go back to previous menu.
To change Display mode from WAVE to DATA and vice versa.
To get out of Site guidance mode.
7. Speaker: Outputs Doppler sounds.
8. LCD display: Displays waveform, numerical data, Heart Rate and menu for mode settings. See “§ 6-2. LCD Display” for details.

2-2. Back side view and Probe

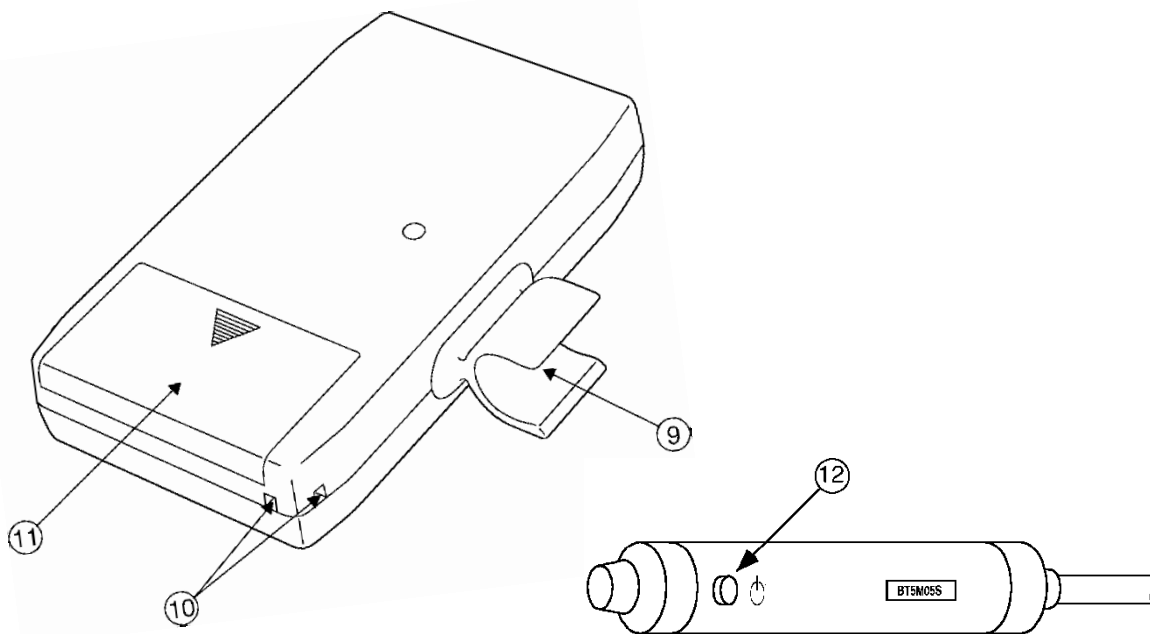

9. Probe holder: For probe placement when not in use.
10. Strap holes: To connect neck strap (Option).
11. Battery cover: For battery placement.
12. Probe button:  To turn the unit ON.
To freeze the waveform & numerical data when power is ON.
To turn the unit OFF, press it longer than 2 sec.

3. Quick start

3-1. Turning the unit ON / OFF

- (1) Set the alkaline battery in the unit.
(See “§ 3-2. Checking battery level and replacing battery”.)
- (2) Connect the probe to the Bidop so that the polarity mark  will be placed under ▼ mark.
- (3) Press the probe button or shuttle button to turn the unit ON. Press button the second time longer than 2 sec. to turn it OFF.

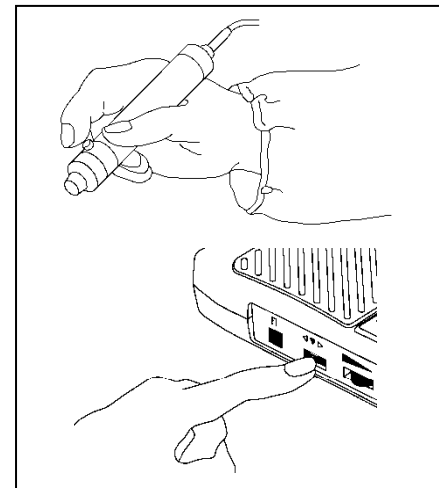
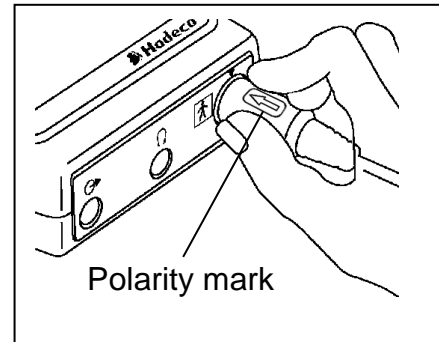

► **Low battery:**

When battery is low, low battery indicator  appears. Replace the battery for further use.

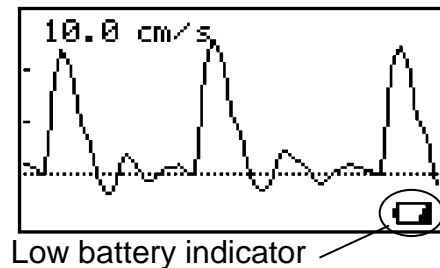

► **Automatic shut-off:**

When the AUTO-OFF is ON, if the unit is left on, the power is automatically shut off after following time passes:

- (a) 15 minutes when in measurement. (35 min. for FHR waveform mode)
- (b) 2 minutes when no signal.
- (c) 5 minutes when on freeze mode.

Note: If Automatic shut-off functions while on Freeze mode, Bidop will revert to Freeze mode and display the frozen waveform on LCD by turning the unit on.

► **Error message:**

In case any inappropriate probe is connected to the unit, error message as shown right will be displayed.



3-2. Checking battery level and replacing battery.

- (1) Turn the unit on and press Shuttle button to display Menu and battery level indicator will be shown on top right of MENU.

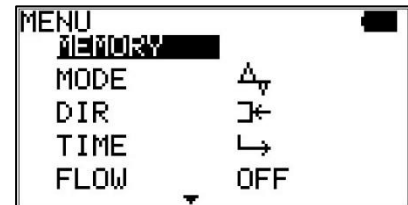

It shows 4 levels as shown below.

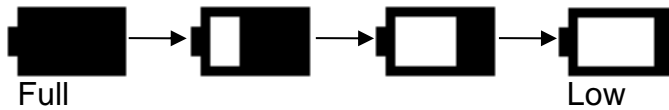

When battery is low, replace the battery with new one as follows.

- (2) When you replace battery, turn the unit off and open the battery cover as shown right.

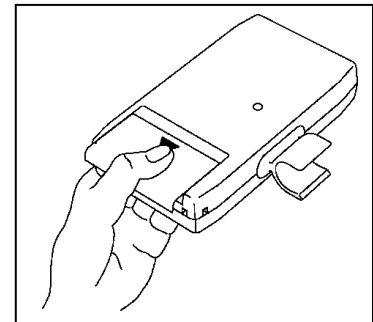

- (3) To prevent any damage to the battery terminal, please insert the battery to battery box as shown right.

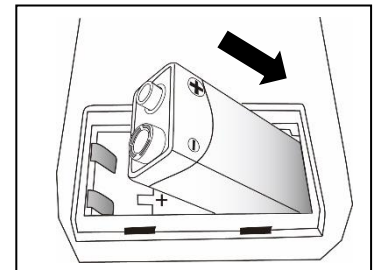

- (4) Use a 9 volt ALKALINE square type battery. A non-alkaline may cause a shortage of power.
Set the battery in the unit ensuring that the positive and negative terminals correspond to the + and - marks on the label in battery box, respectively.

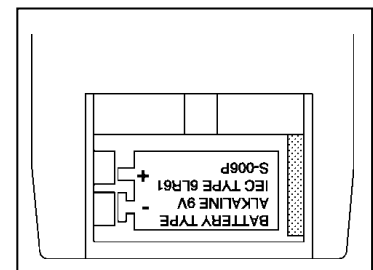

Note: Use the battery composed in the package as a standard component for performing operation check only.

3-3. Measuring blood velocity

3-3-1. Normal mode

This section explains the fundamental use of measuring blood velocity. Refer to “§ 4. MENU and Mode settings” for various uses.

- (1) Put ultrasonic gel on the probe top or patient skin.

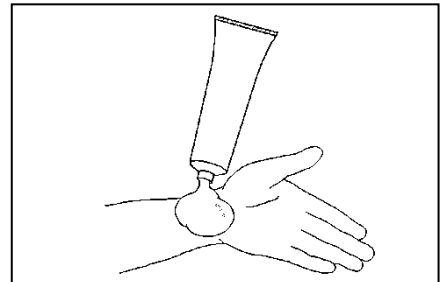

- (2) Put the probe on the measurement area and move it slowly to locate the point where the maximum Doppler sounds are heard. An ideal probe angle to the vessel is approximately 45° to 60° .

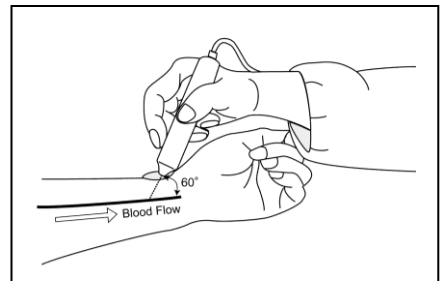

- (3) When the waveform becomes rhythmical and stable, wait more than 5 sec. without moving probe and press the probe button to freeze the waveform.

Note: Pressing probe button longer than 2 sec. will turn the unit OFF.

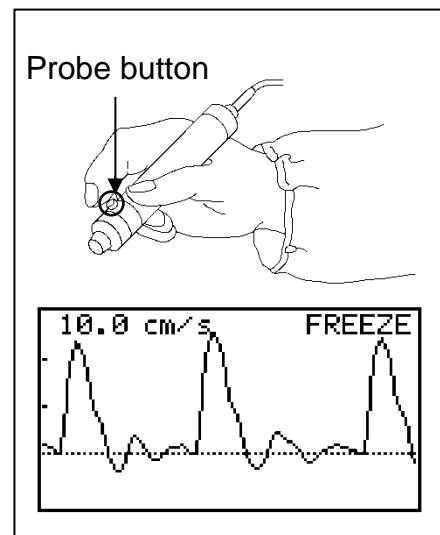

- (4) To get numerical data, press BACK button or go to menu and change the DISP mode to DATA.

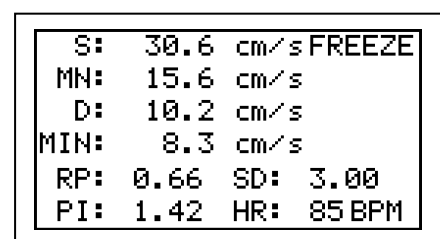

Note: See “§ 4-2-g. DISP” for operation. Also, see “§6-3. Numerical Data” for the parameters.

(5) Headset can be used to listen to Doppler sounds. It will cut off the speaker.

► **To store the data:**

If you wish to store the waveform and numerical data on the memory, do the following procedures;

1. Press the Shuttle Button to display MENU and press it again on MEMORY to go to MEMORY menu.



2. Press the Shuttle button on STORE and next memory number available for storage will be displayed as shown in the right.

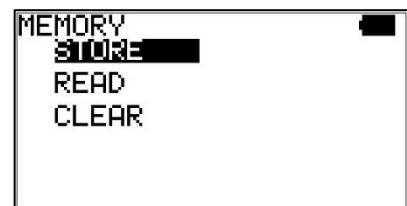

Turn Shuttle Button up and down to change the memory number, if necessary.

3. Press the Shuttle button to store the data.

► **To display stored data:**

1. Press the Shuttle button to go to MEMORY menu.



2. Press the Shuttle button on READ and select the memory number with "*" by turning the Shuttle Button up and down.

3. Press the Shuttle button to show the waveform. To show next waveform, turn the Shuttle button up and down.

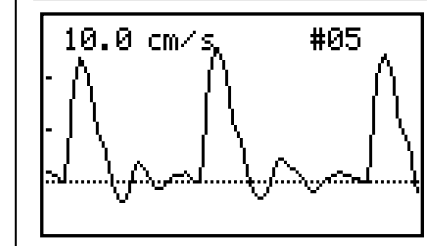

► LCD Backlighting time:

LCD backlighting time can be adjusted on BACKLIGHT mode setting. See “§4-2-r. OTHERS – BACKLIGHT” for details. Press BACK button longer than 2 sec. to turn it ON / OFF instantly during testing.

3-3-2. Site guidance mode

This mode allows you to easily proceed multiple Smart-V-Link testing by just pressing probe button without connecting Smart-V-Link.

Register **Abbreviated site & test names** on the unit through Smart-V-Link to activate this mode. Once the names are registered, the unit will show each of names at the beginning of each testing to let you know where to test next.

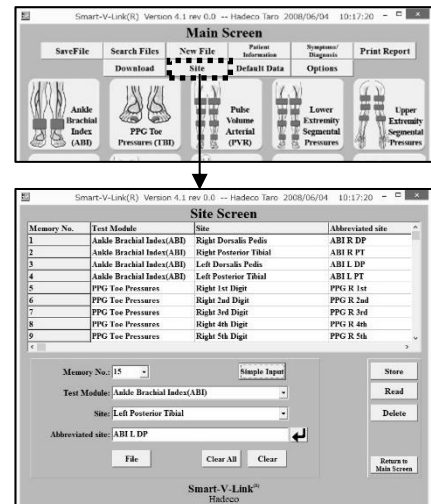

<Site Screen of Smart-V-Link>

► Preparation for site guidance mode:

- (1) Connect the unit to the computer with the USB cable and start Smart-V-Link.
- (2) Go to Site Screen and input abbreviated site & test name for each waveform memory and then store the names on the unit.
- (3) Go to MEMORY menu and clear ALL memory data on the unit before newly starting the site guidance mode.

See the section “§.4-1-4. Site” on Smart-V-Link, V4.1 or over, operating manual for more details.

► **Site guidance mode procedures:**

- (1) Turn the unit off and on and the 1st guidance with memory number and abbreviated site & test name will appear as shown in the right.

Note: The first memory number available will be selected automatically.

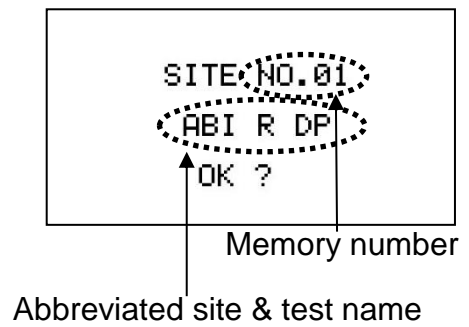

- (2) Press the probe button to start monitoring waveform.
Press Back button to get out of “Site guidance mode” for normal mode operation.

Probe button

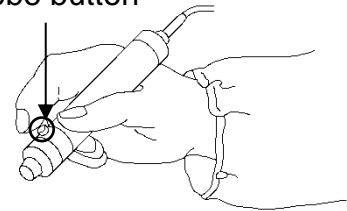

- (3) Press the probe button the 2nd time to freeze the waveform when it becomes stable and the 2nd guidance “STORE?” as shown in the right will appear.

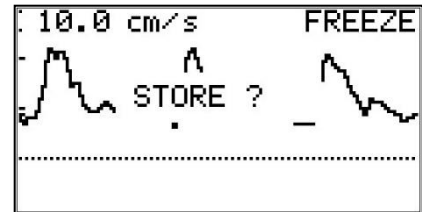

- (4) Press probe button the 3rd time to store the frozen waveform data on the designated memory number.

Probe button

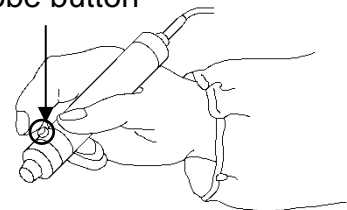

- (5) The 1st guidance for the next testing will appear as shown in the right. Repeat steps #(5) to #(7) until all testing is completed.



Press probe button when the message shown right is displayed upon completion of all testing and the unit will get out of site guidance mode.

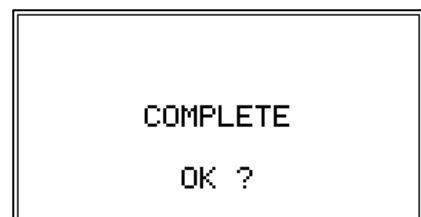

3-4. Measuring heart rate (2MHz only)

This section explains the fundamental use of measuring heart rate. Refer to “§ 4. Menu and Mode settings” for various uses.

(1) Connect the 2 MHz probe to the Bidop and turn the unit ON.

(2) Press the Shuttle button to display MENU and set DISP mode for **WAVE** or **DATA**. If necessary, change the upper and lower limits by turning the Shuttle button up and down between 60 and 220 BPM at 5 BPM intervals and press the Shuttle button to set them. See “§4-2-i. UPPER” and “§4-2-j. LOWER” for details.

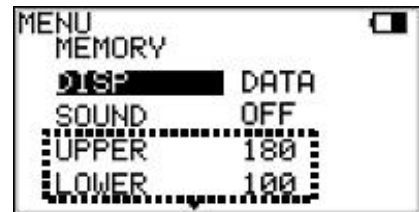

(3) Put ultrasonic gel on the probe top or patient skin surface.

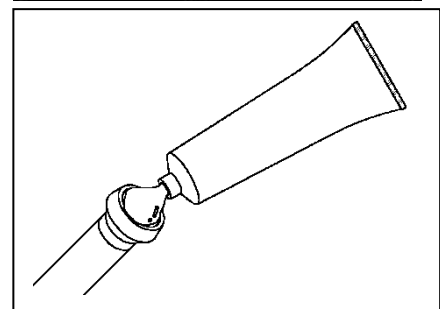

(4) Put the probe on the measurement area and move it slowly to locate the point where the maximum sounds are heard.

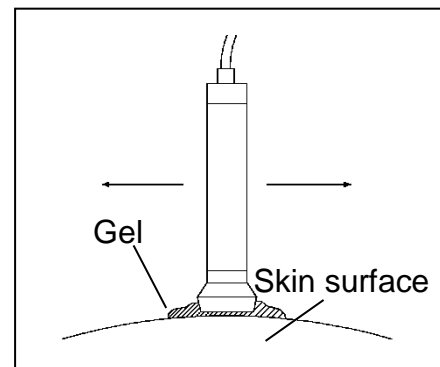

(5) When the heart rate becomes stable, press the probe button, or BACK button while using waterproof probe, to freeze it. In case FHR exceeds the upper and lower limits, LCD will start flashing and also, beep sounds will be heard if SOUND mode is set for ON. See “§4-2-h. SOUND” for details.

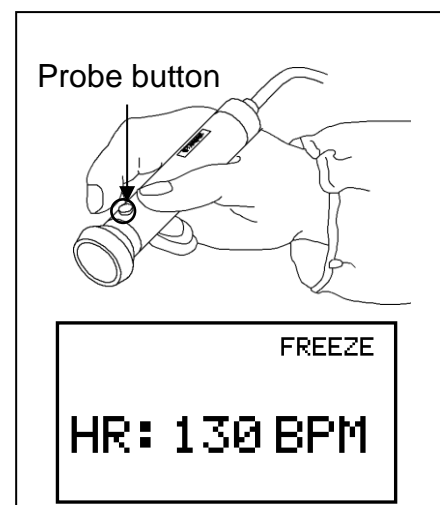

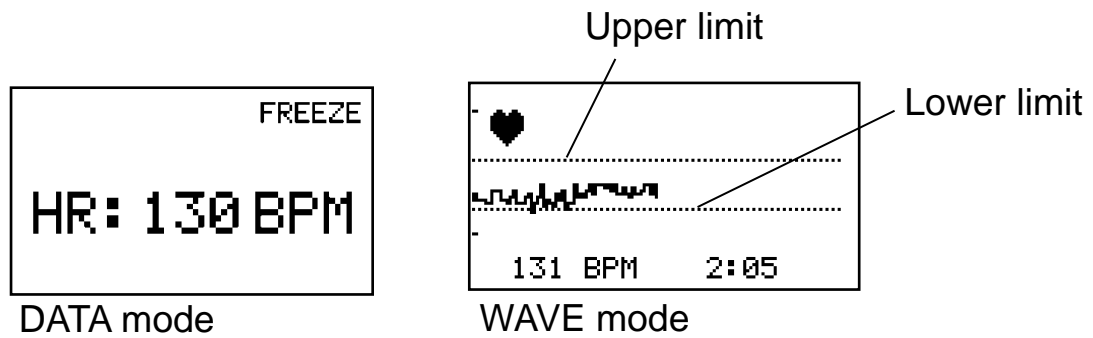

To store the monitoring waveform data on the memory, follow the step “To store the data” in “§3-3-1. Normal mode”.

Note1: Numerical heart rate can't be stored on the memory.

Note2: If the asterisk (*) is shown above the frozen heart rate as a calculation error indicator, press probe button and do the testing again.

Manual counting mode is available if heart rate cannot be calculated, see “§ 6-2-2. Heart Rate mode”.

(6) Headset can be used to listen to Doppler sounds. It will cut off the speaker.

3-5. 2 MHz BEEP mode

2 MHz BEEP mode is available when 2 MHz probe is connected and it displays blood velocity waveform and beeps when velocity exceeds the limit.

(1) Connect the 2 MHz probe to the Bidop and turn the unit ON.

(2) Press Shuttle Button to display MENU and set DISP mode for BEEP.

LIMIT-1 and LIMIT-2 menu will be shown as shown in the right.

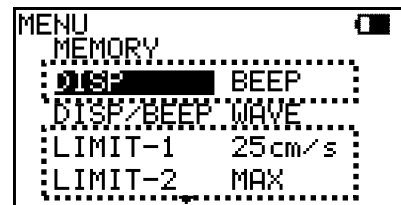

(3) Change the LIMIT-1 by turning the Shuttle button Up & Down between 0 and 120 cm/s at 1 cm/s intervals and press the Shuttle button to set it.

Set LIMIT-2 for MAX or AVE as follows;

MAX: To beep when max velocity exceeds upper limit.

AVE: To beep when average velocity exceeds upper limit.

(4) Put ultrasonic gel on the probe top or the skin surface.

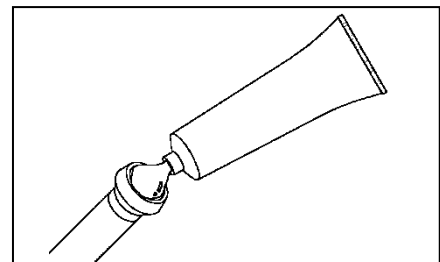

(5) Put the probe on the measurement area and move it slowly to locate the point where the maximum sounds are heard.

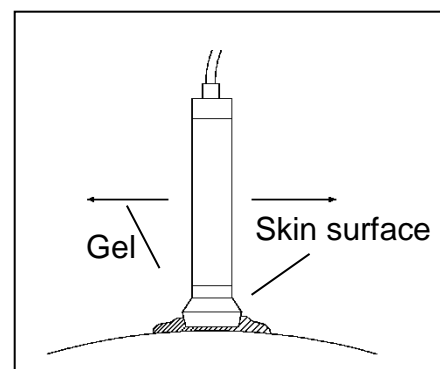

(6) When velocity exceeds the limit, beep sounds will be heard.

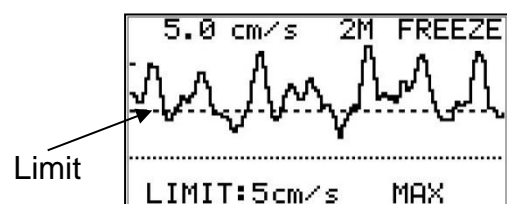

4. Menu and Mode settings

4-1. Menu

By using Shuttle buttons, various mode settings can be selected on Menu mode. Some of the menus consist of sub-menu(s).





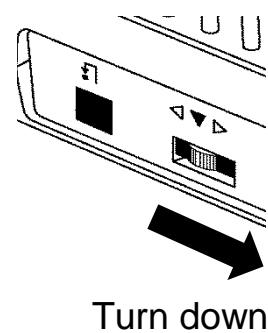
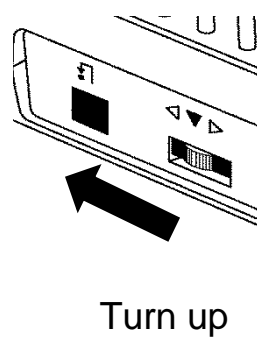
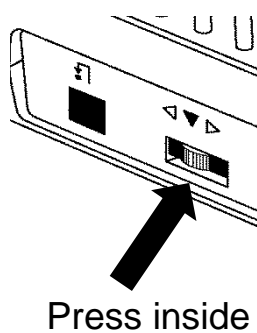
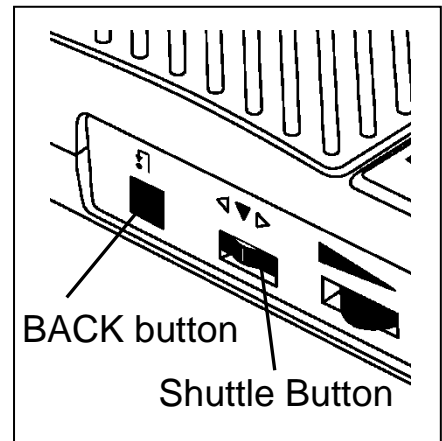

4-1-1. Menu operation

- Press Shuttle Button inside to show MENU depending on Basic mode.
- Select the mode by turning Shuttle Button up and down and selected mode will be highlighted. Press it once or twice to change the mode setting.
- For MEMORY and OTHERS in MENU, pressing Shuttle Button shows sub menu for further mode settings.
- Press BACK button to go back to main menu from sub menu or get out of the menu mode.







4-1-2. MENU for Blood Velocity Measurement mode

Selections in bold face in the table above are defaults.

Menu	Sub Menu	Selections	Reference in §4-2
MEMORY	READ	1 to 30, FREEZE	b. MEMORY - READ
	CLEAR	1 to 30, ALL	c. MEMORY - CLEAR
MODE		COMPOUND  SEPARATION 	d. MODE
DIR		FORWARD  REVERSE 	e. DIR
TIME		NORMAL  , SLOW 	f. TIME
FLOW		ON, OFF	v. FLOW
DIAMETER		0.1mm – 20.0mm	w. DIAMETER
OTHERS	LANGUAGE	ENGLISH , DEUTSCH, ITALIANO, ESPANOL, FRANCAIS, TURKCE, POLSKI	m. OTHERS - LANGUAGE
	FREEZE	MANUAL , AUTO	t. OTHERS - FREEZE
	UNIT	cm/s , kHz	n. OTHERS - UNIT
	FILTER	ARTERIAL , VENOUS	o. OTHERS - FILTER
	SMOOTH	NORMAL , LOW -PASS	p. OTHERS - SMOOTH
	DISP	WAVE , DATA	g. DISP
	CAL	ON, OFF	q. OTHERS - CAL
	BACKLIGHT	ON, OFF , 10 to 60 (10 sec. steps)	r. OTHERS - BACKLIGHT
	AUTO-OFF	ON , OFF	s. OTHERS - AUTO-OFF
	PRB20MHz	ON, OFF	u. OTHERS - PRB20MHz

Note: PRB20MHz menu is only available when either a 20MHz probe or no probe is connected.

4-1-3. MENU for Blood Velocity Freeze mode

Menu	Sub Menu	Selections	Reference in §4-2
MEMORY	STORE	1 to 30, FREEZE	a. MEMORY - STORE
	READ	1 to 30, FREEZE	b. MEMORY - READ
	CLEAR	1 to 30, ALL	c. MEMORY - CLEAR
MODE		COMPOUND  SEPARATION 	d. MODE
DIR		FORWARD  REVERSE 	e. DIR

DISP		WAVE, DATA	g. DISP
FLOW		ON, OFF	v. FLOW
DIAMETER		0.1mm – 20.0mm	w. DIAMETER
OTHERS	LANGUAGE	ENGLISH, DEUTSCH, ITALIANO, ESPANOL, FRANCAIS, TURKCE, POLSKI	m. OTHERS - LANGUAGE
	FREEZE	MANUAL, AUTO	t OTHERS - FREEZE
	BACKLIGHT	ON, OFF, 10 to 60 (10 sec. steps)	r. OTHERS - BACKLIGHT
	AUTO-OFF	ON, OFF	s. OTHERS - AUTO-OFF

4-1-4. MENU for Heart Rate mode (Measurement and Freeze)

Menu	Sub Menu	Selections	Reference in §4-2
MEMORY	STORE	1 to 30, FREEZE	a. MEMORY - STORE
	READ	1 to 30, FREEZE	b. MEMORY - READ
	CLEAR	1 to 30, ALL	c. MEMORY - CLEAR
DISP		WAVE, DATA, BEEP	g. DISP
SOUND		ON, OFF	h. SOUND
UPPER		60 to 220 (every 5 BPM)	i. UPPER
LOWER		60 to 220 (every 5 BPM)	j. LOWER
OTHERS	LANGUAGE	ENGLISH, DEUTSCH, ITALIANO, ESPANOL, FRANCAIS, TURKCE, POLSKI	m. OTHERS - LANGUAGE
	BACKLIGHT	ON, OFF, 10 to 60 (10 sec. steps)	r. OTHERS - BACKLIGHT
	AUTO-OFF	ON, OFF	s. OTHERS - AUTO-OFF

Note1: STORE menu is available when on WAVE & freeze mode only.

Note2: When on Freeze mode, DISP mode can't be changed.

4-1-5. MENU for 2MHz BEEP Measurement mode

Menu	Sub Menu	Selections	Reference in §4-2
MEMORY	READ	1 to 30, FREEZE	b. MEMORY - READ
	CLEAR	1 to 30, ALL	c. MEMORY - CLEAR
DISP		WAVE , DATA, BEEP	g. DISP
DISP/BEEP		WAVE , DATA	g. DISP
LIMIT-1		0 – 120cm/s or 0.0kHz – 12.0kHz	k. LIMIT-1
LIMIT-2		MAX , AVE	l. LIMIT-2
OTHERS	LANGUAGE	ENGLISH , DEUTSCH, ITALIANO, ESPANOL, FRANCAIS, TURKCE, POLSKI	m. OTHERS - LANGUAGE
	UNIT	cm/s , kHz	n. OTHERS - UNIT
	BACKLIGHT	ON, OFF , 10 to 60 (10 sec. steps)	r. OTHERS - BACKLIGHT
	AUTO-OFF	ON , OFF	s. OTHERS - AUTO-OFF

4-1-6. MENU for 2MHz BEEP Freeze mode

Menu	Sub Menu	Selections	Reference in §4-2
MEMORY	STORE	1 to 30, FREEZE	a. MEMORY - STORE
	READ	1 to 30, FREEZE	b. MEMORY - READ
	CLEAR	1 to 30, ALL	c. MEMORY - CLEAR
DISP		WAVE , DATA, BEEP	g. DISP
DISP/BEEP		WAVE , DATA	g. DISP
OTHERS	LANGUAGE	ENGLISH , DEUTSCH, ITALIANO, ESPANOL, FRANCAIS, TURKCE, POLSKI	m. OTHERS - LANGUAGE
	BACKLIGHT	ON, OFF , 10 to 60 (10 sec. steps)	r. OTHERS - BACKLIGHT
	AUTO-OFF	ON , OFF	s. OTHERS - AUTO-OFF

Button functions limited to Heart Rate mode;

- Shuttle (up & down): To restart waveform monitoring when on WAVE mode.
- Shuttle (up): To start and stop manual counting of heart rate when on DATA mode. See “§ 6-2-2. Heart Rate mode” for details.
- Shuttle (down): To show next page of monitoring waveform when on Freeze mode.
- BACK: To freeze and unfreeze the waveform & heart rate.

4-2. Mode setting details

a. MEMORY - STORE

- (1) STORE menu is available when on freeze mode only. The first memory number available will be selected automatically on STORE. If necessary, change the number where to store waveform data by turning Shuttle Button up and down.

Note: The memory number with "*" indicates memory area where other data have been already stored.

- (2) Press Shuttle Button to store the data into the memory and it will go back to frozen waveform automatically.

Note: If other data have been already stored in memory number storing, a confirmation of "OVERWRITE?" will be shown. Press Shuttle Button to overwrite, or BACK to cancel it for selecting other memory number available.

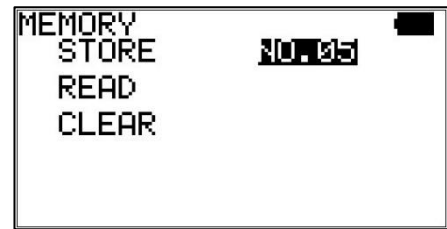

< On normal mode >



< On site guidance mode >

b. MEMORY - READ

- (1) Select the memory number where you wish to read waveform data by turning Shuttle Button up and down.
- (2) Press Shuttle Button to show the waveform. To show next waveform stored, press Shuttle up and down.

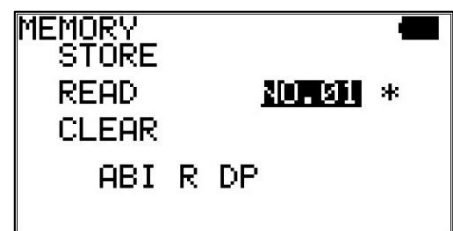

Note: Any frozen waveform is stored temporarily in memory area of FREEZE separated from regular 30 memories. It can be re-shown by reading from memory FREEZE and won't be erased until next waveform is frozen or unit is turned off.

c. MEMORY - CLEAR

(1) Select the memory number you wish to clear the data for. The number with "*" indicates memory area where data have been already stored.

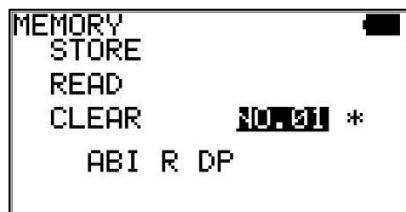

(2) Press Shuttle Button and then the confirmation screen with waveform data will be displayed as shown in the right. Press Shuttle Button to clear the memory, or press BACK button to cancel.

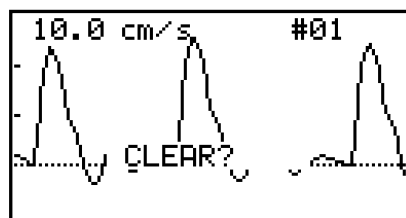



(3) To clear all the data except FREEZE in the memory at once, select and press on ALL and follow the instruction.



d. MODE (Baseline mode)

(1) Press Shuttle Button to change the baseline mode as follows:

- Compound mode:  Combined forward and reverse components
- Separate mode:  Separation of forward from reverse component

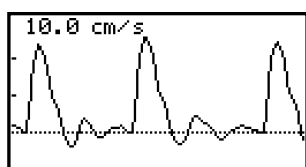

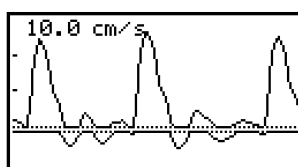

Compound



Separate

e. DIR (Flow direction)

(1) Press Shuttle Button to change waveform polarity as follows:

- Forward:  Flow toward probe is processed as positive component.
- Reverse:  Flow away from probe is processed as positive component.

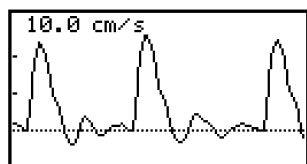

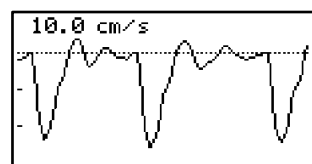

Forward



Reverse

f. TIME (Time scale)

(1) Press Shuttle Button to change the time scale as follows:

- Normal:  For arteries (2.56 sec./screen)
- Slow:  For veins (25.6 sec./screen)

g. DISP (DISP, OTHERS – DISP, DISP/BEEP)

(1) Press Shuttle Button to change the Display mode as follows:

<DISP>

- WAVE: Waveform
- DATA: Numerical data
- BEEP: 2MHz BEEP mode

<DISP/BEEP>

- WAVE Waveform for 2MHz BEEP mode
- DATA Numerical data for 2MHz BEEP mode

Note: On heart rate mode, display mode cannot be changed when on Freeze mode. When on heart rate measurement mode with WAVE mode, turning Shuttle button up & down to restart the monitoring.

h. SOUND (Beep sound for HR)

Set SOUND mode for ON to activate beep sounds when heart rate gets out of upper and lower limits during the test except 1st 30 sec.

(1) Press Shuttle Button to change beep sound ON / OFF.

i. UPPER (Upper limit for HR)

In case heart rate exceeds the upper limit during the test except 1st 30 sec., LCD will start flashing.

(1) Turn Shuttle Button up and down to select the upper limit in 5 BPM steps and press the button to set it.

j. LOWER (Lower limit for HR)

In case heart rate gets below lower limit during the test except 1st 30sec., LCD will start flashing.

- (1) Turn Shuttle Button up and down to select the lower limit in 5 BPM steps and press the button to set it.

k. LIMIT-1 (Limit for 2MHz BEEP mode)

In case maximum or average blood velocity exceeds the limit, beep sound will be heard.

- (1) Turn Shuttle Button up and down to select the limit in 1 cm/s (0.1 kHz) steps and press the button to set it.

l. LIMIT-2 (Maximum / Average for 2MHz BEEP mode)

- (1) Press Shuttle Button to change the mode as follows:

- MAX: Beeps when maximum velocity exceeds limit.
- AVE: Beeps when average velocity exceeds limit.

m. OTHERS - LANGUAGE

- (1) Turn Shuttle Button up and down to select the language you wish for menus and messages, and press the button to set it.

n. OTHERS - UNIT (cm/s / kHz)

- (1) Press Shuttle Button to change the unit of blood flow as follows:

- cm/s: Blood flow velocity
- kHz: Doppler-shifted frequency

o. OTHERS - FILTER (Arterial / Venous filter)

The high-pass filter cuts off Doppler signals with lower frequencies than filtering frequency (200 or 80 Hz) for optimal audibility.

- (1) Press Shuttle Button to change the filter as follows:

- ARTERIAL: For arteries (200 Hz)
- VENOUS: For veins (80 Hz)

p. OTHERS - SMOOTH (Smoothing filter)

- (1) Press Shuttle Button to change smoothing frequency as follows:

- NORMAL: For normal signals (10 Hz)
- LOW-PASS: For noisy signals (5 Hz)

q. OTHERS - CAL (Calibration)

(1) Press Shuttle Button to change the CAL mode as follows:

- ON: Displays 4 step (3, 2, 1, 0, -1 kHz) calibration waveform.
- OFF: Measurement mode

4 step calibration

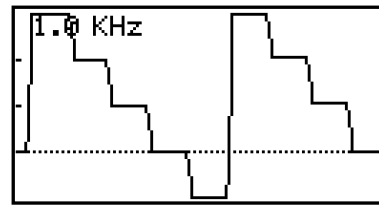

r. OTHERS - BACKLIGHT

LCD backlighting time can be adjusted on BACKLIGHT mode.

(1) Turn Shuttle Button up and down to select the time and press the button to set it.

- ON: Turns backlight always on.
- OFF: Turns backlight always off.
- 10 ... 60: Auto-off time with 10 sec. steps

BACKLIGHT can be also turned ON / OFF by pressing BACK button longer than 2 sec. When BACKLIGHT is set for Auto-off, backlight goes off in auto-off time of no operation and any button operation will turn the light on again.

s. OTHERS - AUTO-OFF (Automatic shut-off)

(1) Set it for ON / OFF for auto-off on / off.

See “§3-1. Turning the unit ON / OFF” for more details.

t. OTHERS - FREEZE

(1) Set FREEZE for AUTO to freeze the waveform automatically when it becomes stable. Set it for MANUAL for freezing waveform manually.

u. OTHERS - PRB20MHz

For 20MHz probe, set 20MHz mode for ON before connecting the probe.

v. FLOW (Blood volume flow) / w. DIAMETER (Estimated vessel diameter)

Blood volume flow will be calculated on blood velocity measurement & freeze modes when FLOW is set for ON.

- (1) Press Shuttle Button to set FLOW mode for ON and DIAMETER menu will be shown as shown below.

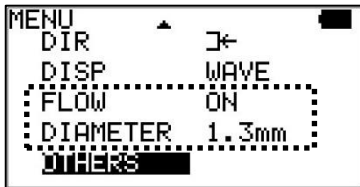

- (2) Set the estimated vessel diameter by turning Shuttle button Up & Down for anywhere between 0.1 and 20.0 mm at 0.1 mm intervals and Bidop will calculate and show blood volume flow of numerical data MAX (Maximum) and MN (Mean) on DATA display.

Note: Set DISP mode for DATA to display numerical data and press BACK button to show flow MAX and MN on 2nd page of numerical data as shown below.

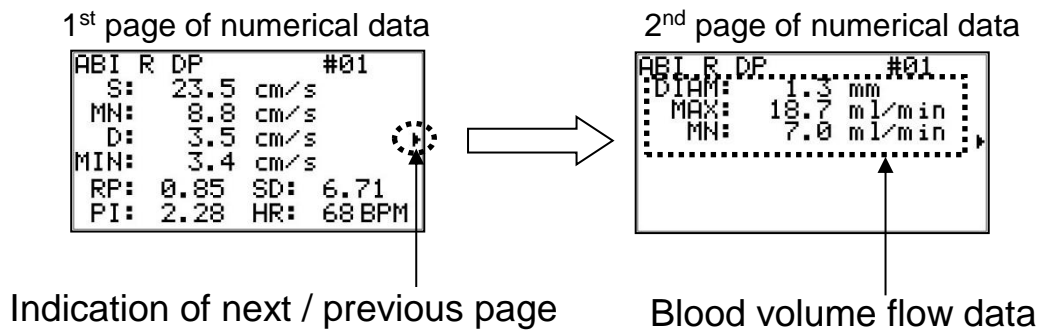

5. Maintenance

5-1. Performance check by user

Perform the following performance checks at least once a year:

- (1) Make sure if there is no damage and/or crack on the main unit and probe.
- (2) Shake the main unit and make sure if there are no sounds inside from internal components coming off.
- (3) Turn the unit on and make sure if the LCD displays normally.

5-2. Cleaning

PROBE:

Remove the Doppler gel from the probe head after use. Clean the probe using damp cloth and then wipe with a soft dry cloth, but take great care that any water may not penetrate into the probe. If using disinfectant, please consult in advance with the manufacturer.

MAIN UNIT:

To clean the main unit, use a damp cloth and then wipe with a soft dry cloth, but take great care that any water may not penetrate into the unit. Check the unit by maintenance procedures mentioned in “5-1. § Performance check by user”.

5-3. Probe sterilization

5-3-1. Sterilizable probes (Amplifier required)

Small pencil	8MHz:	VRP-08
	10MHz:	VRP-10
	20MHz:	VRP-20
Long	8MHz:	LRP-08
	10MHz:	LRP-10
Flat	8MHz:	FDP-08
Autoclavable	8MHz:	ACP-08
Curved pencil	10MHz:	CRP-10H*
	20MHz:	CRP-20H*
	20MHz:	CRP-20H1N*

Bayonet	10MHz:	NRP-10H*
	20MHz:	NRP-20H*
Flexible	10MHz:	NRP-10HF*
	20MHz:	NRP-20H1NF*
Single use	10MHz:	NDP-10H*
	20MHz:	NDP-20H*

*: *Except European Union Countries.*

5-3-2. Sterilization

Only sterilizable probes can be sterilized. Do not sterilize other type of probes including amplifiers as well as main unit.

Warnings:

Sterilizable probes are not sterilized before shipment.

They must be sterilized before use as follows:

Sterilization limits:

All sterilizable probes except ACP and FDP probe: Up to 50 times

ACP probe: Up to 5 times by steam autoclave

FDP probe: Up to 5 times

Note: Do not exceed sterilization limits or it may cause damage to probes.

Cautions:

1. Except ACP probe, do not sterilize probes by steam autoclave nor put them in washer disinfectant or it will damage probes.
2. ACP probe should be sterilized by steam autoclave as described in section "Instructions for sterilization" below.

Instructions for sterilization:

Point of preparation: No particular requirements.

Preparation for cleaning: No particular requirements.

Cleaning:

Automated: Do not do automated cleaning of probes other than ACP probe.

Manual: Do not soak probes into medicinal solution. Wipe any contamination from probes with damp cloth.

Disinfection: Not applicable

Sterilization:

Sterilizable probes except ACP probe:

Low temperature plasma sterilization (Hydrogen peroxide low temperature plasma sterilization), under 60°C.

Sterilization system is compatible with only the STERRAD® by Johnson & Johnson, K.K. sterilization system as follows:

- STERRAD®50
- STERRAD®100S (only short cycle)
- STERRAD®200 (only short cycle)
- STERRAD®NX (only standard cycle)
- STERRAD®100NX (only standard cycle)

Do not put liquid, powder & cellulose inside sterilization equipment or it may reduce effectiveness of sterilization because these substances absorb hydrogen peroxide. Eliminate water on surface of probe because it may reduce effectiveness of sterilization.

Sterilization should be performed in accordance with instructions of the sterilization equipment.

ACP probe: Steam autoclave

- 30 minutes at 121 °C
- 4 minutes at 134 °C

Do not expose probes to temperatures exceeding 134 °C
Sterilization should be performed in accordance with instructions of the sterilization equipment.

Drying:

Sterilizable probes except ACP probe:

No particular requirements.

ACP probe: Dry it well after the sterilization.

Maintenance: No particular requirements.

Inspection and Function Testing:

No cracks nor contaminations in appearance.

Connect the probe to main unit and make sure if you hear Doppler sounds properly when you rub probe tip.

Packaging: No particular requirements.

Storage: No particular requirements.

Manufacturer contact:

Hadeco, Inc.

2-7-11 Arima, Miyamae-ku, Kawasaki, 216-0003, Japan

Tel : +81-44-877-4361 Fax : +81-44-855-7301

The instructions provided above have been validated by the medical device manufacturer as being CAPABLE of preparing a medical device for reuse. It remains the responsibility of the processor to ensure that the processing as actually performed using equipment, materials and personal in the processing facility achieve the desired result. This requires validation and routine monitoring of process. Likewise any deviation by the processor from the instruction provided should be evaluated for effectiveness and potential adverse consequences.

5-4. Warranty

Guarantee period:

* Frequency

Main unit		Two(2) years
Probe	BT*M05S8C(A), BF8M15S8A, BP*M05S8A, VRP-*, LRP-*, BDP*MS8, PG-21,	One(1) year
	ACP-08	Either one year from the date of purchase or within 5 times of autoclave sterilization.
	FDP-08	Either 3 months from the date of purchase or within 5 times of sterilization.
Probe <i>Except</i> <i>European</i> <i>Union</i> <i>Countries</i>	TP-01	One(1) year
	CRP-*H, CRP-20H1N, NRP-*H	Six(6) months
	NRP-10HF,NRP-20H1NF	Three(3) months
	Single use probe	Either one year from the date of purchase or out of box failure

The guarantee period is after the date of purchase when used under normal condition. In the event of any trouble during the warranty period, please contact the dealer from who you purchased the unit. In case the warranty period is over, please consult the dealer for a charged service.

6. Supplemental information

6-1. Basic mode

Eight Basic Operation Modes:

- | | |
|--------------------------------|--|
| • Blood Velocity - Measurement | For measuring blood velocity |
| • Blood Velocity - Freeze | For observing waveforms and numerical data |
| • Heart Rate - Measurement | For measuring heart rate |
| • Heart Rate - Freeze | For observing heart rate and graph |
| • 2 MHz BEEP - Measurement | For precordial blood velocity |
| • 2 MHz BEEP - Freeze | For observing waveforms and numerical data |
| • Menu | For changing other mode settings |

Changing mode with probe button (Measurement / Freeze)

Press the probe button to go to freeze mode and press it again to get back to measurement mode.

Note: If the probe button is pressed longer than 2 sec., the unit will turn OFF.

With 2 MHz probe, you can also change mode (Measurement / Freeze) by pressing BACK button of the unit.

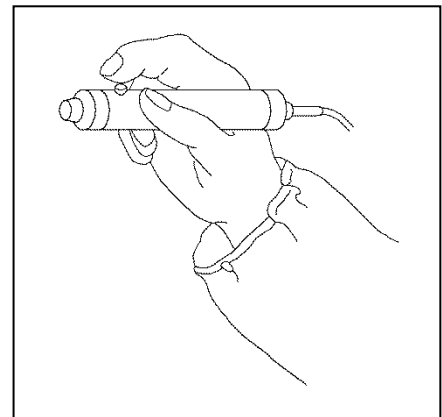

6-2. LCD display

6-2-1. Blood Velocity mode

► Waveforms:

- (1) The base line is automatically located at optimal position for each waveform. Bidop has 4 base lines, the bottom, 1/4 from the bottom, the center, and 3/4 from the bottom. The waveform amplitude is automatically adjusted for optimal observation.

- (2) The amplitude scale (velocity or frequency per division) is displayed on top left of LCD.

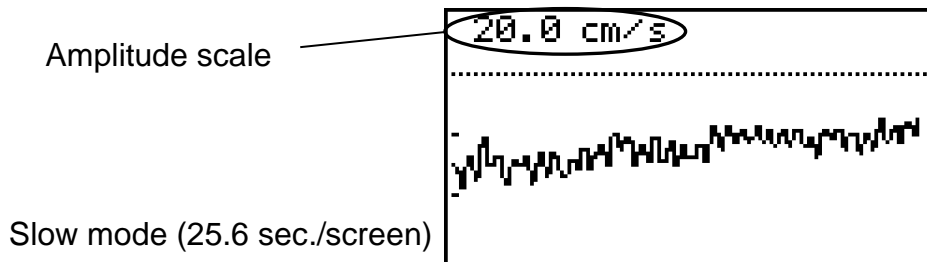
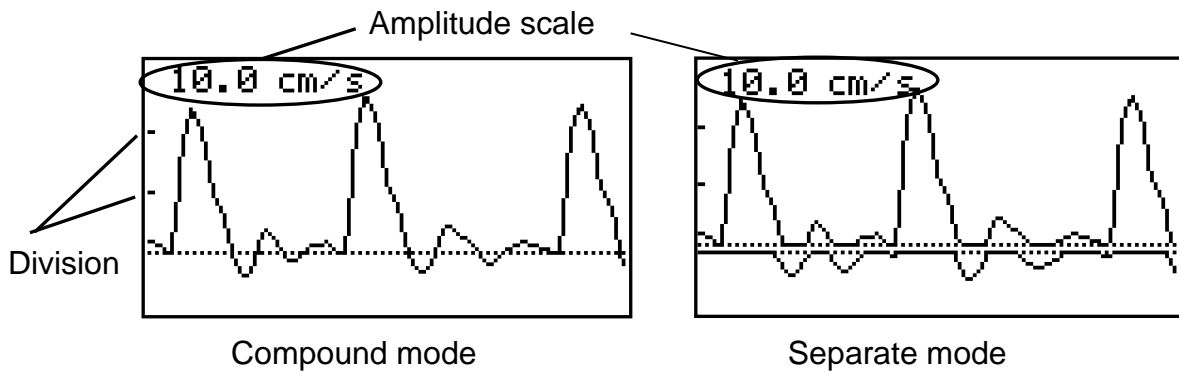

- (3) When pressing probe button to freeze the waveform, Bidop will stop monitoring and will display frozen waveform with "FREEZE".

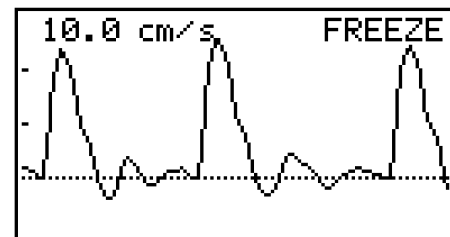

Memory number is shown on top right of LCD for waveform read from MEMORY, e.g. "#01"

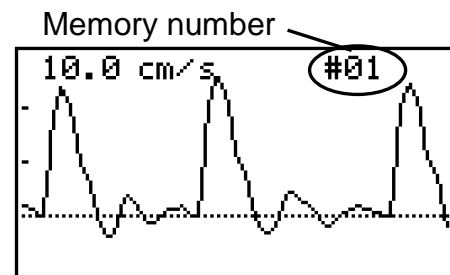

► **Numerical data:**

Following numerical parameters are displayed on DATA mode.

S:	30.6	cm/s
MN:	15.6	cm/s
D:	10.2	cm/s
MIN:	8.3	cm/s
RP:	0.66	SD: 3.00
PI:	1.42	HR: 85BPM

Unit: cm/s

S:	1.12	kHz
MN:	0.11	kHz
D:	0.00	kHz
MIN:	-0.17	kHz
RP:	1.00	SD: **. **
PI:	11.72	HR: 73BPM

Unit: kHz

See “§ 6-3. Numerical Data” for the meaning of abbreviations and the definitions of parameters.

Note: When calculated heart rate is not stable, an asterisk (*) will show left side of “HR”

S:	30.6	cm/s	FREEZE
MN:	15.6	cm/s	
D:	10.2	cm/s	
MIN:	8.3	cm/s	
RP:	0.66	SD:	3.00
PI:	1.42	*HR:	85 BPM

6-2-2. Heart Rate mode (Only 2 MHz probe)

► Numerical heart rate (DATA mode):

Heart rate is displayed based on a 4 beat average once the Bidop gets sufficient data to calculate.

- (1) The heart mark "♥" tracks heart beat while in measurement. The heart mark also indicates the speed of heart movements in 3 different size sizes as follows:

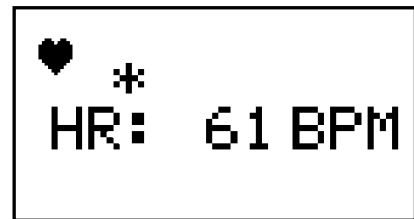

- (2) When calculated heart rate is not stable, the asterisk (*) will show above “HR”.

► Manual counting mode:

- (1) Turn Shuttle up and hold to start manual counting and "M" and the time passed will be shown on the top right while on manual counting mode.

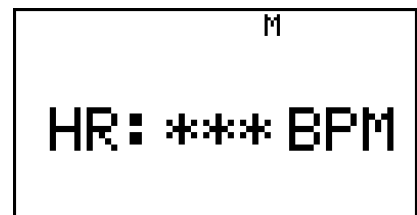

- (2) Count 10 heartbeats and release Shuttle and the heart rate manually counted will be shown.

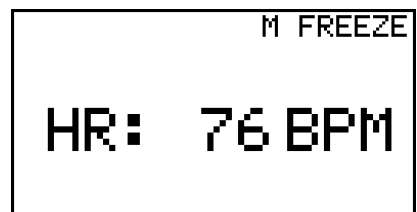

► **Monitoring heart rate in graph (WAVE monitoring mode):**

- (1) The measurement range of heart rate is 60 to 220 BPM.
- (2) Numerical heart rate is displayed on bottom left of LCD.

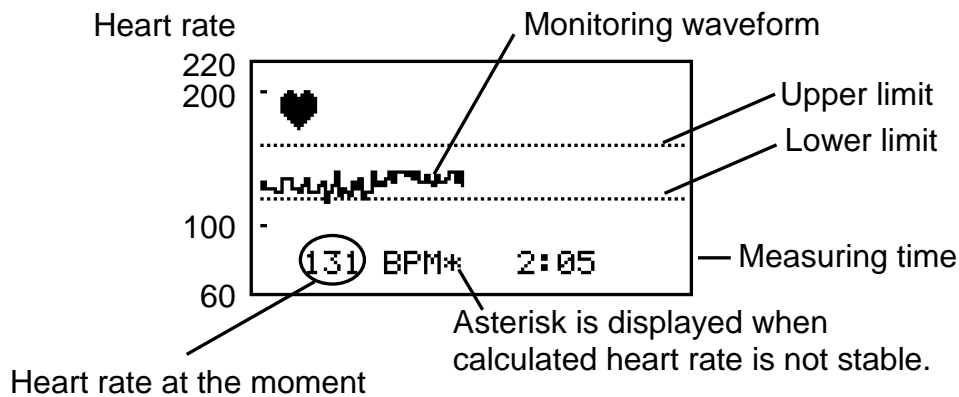

- (3) Heart mark indicates the same way as DATA mode. See previous page.
- (4) Two dotted lines indicate Upper and Lower limits of heart rate. If it gets out of limits during the test except 1st 30 sec., LCD will start flashing.

- (5) When on freeze mode by pressing probe or BACK button, the latest monitoring waveform of up to 33 minutes can be shown over 4 pages on LCD with FREEZE indicator. Turn Shuttle Button down to show next page. (Approx. 8 minutes a page)

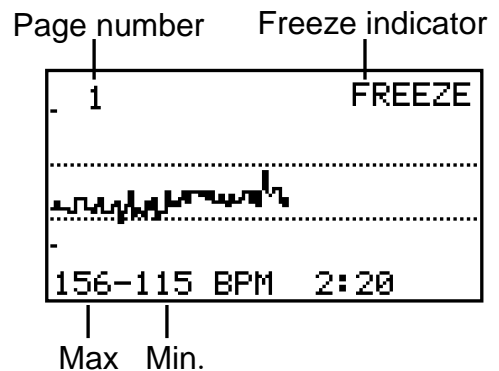

- (6) Memory # is shown on top right of LCD waveform read from MEMORY as shown in the right.

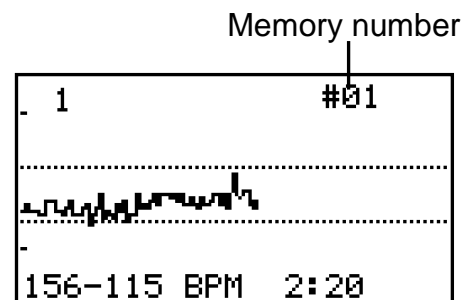

6-2-3. 2 MHz BEEP mode

► Waveforms (DISP/ BEEP: WAVE):

- (1) The base line is fixed 1/4 from the bottom.
- (2) The waveform amplitude is automatically adjusted depending on limit.
- (3) The amplitude scale (velocity or frequency per division) is displayed on top left of LCD.

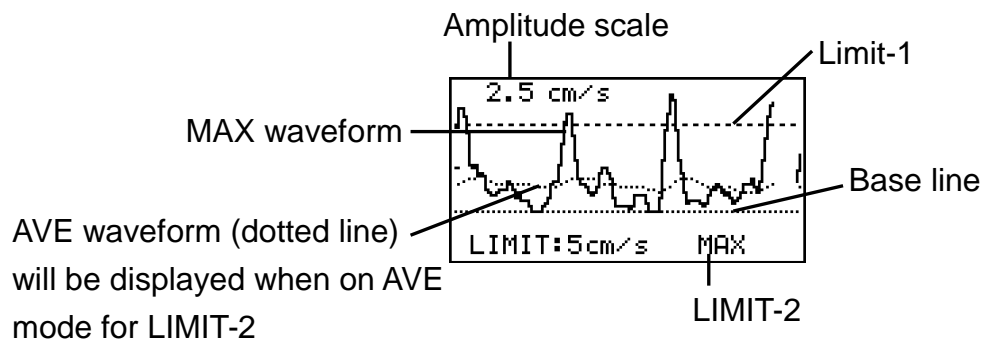

- (4) When pressing probe button to freeze the waveform, Bidop will stop monitoring and will display frozen waveform with "FREEZE".

6-3. Numerical data

Parameters	Abbrs.	Definitions
Systolic velocity [cm/s] or systolic Doppler shift [kHz]	S	
Mean velocity [cm/s] or mean Doppler shift [kHz]	MN	
Diastolic velocity [cm/s] or diastolic Doppler shift [kHz]	D	
Minimum velocity [cm/s] or minimum Doppler shift [kHz]	MIN	
Resistance Parameter	RP	$RP = (S - D) / S$ RP = 1 if waveform goes below base line.
Pulsatility Index	PI	$PI = (S - MIN) / MN$ $PI < 99.99$
S/D ratio	SD	$SD = S / D$
Heart rate [BPM]	HR	
Max volume flow	MAX	
Mean volume flow	MN	
Vessel diameter	DIAM	

Samples displayed on LCD;

S: 30.6 cm/s
MN: 15.6 cm/s
D: 10.2 cm/s
MIN: 8.3 cm/s
RP: 0.66 SD: 3.00
PI: 1.42 HR: 85BPM

Unit: cm/s

S: 1.12 kHz
MN: 0.11 kHz
D: 0.00 kHz
MIN: -0.17 kHz
RP: 1.00 SD: **, **
PI: 11.72 HR: 73BPM

Unit: kHz

6-4. External outputs

6-4-1. Headset

Connect the headset when necessary and it cuts off the speaker.









6-4-2. Communication port (3.5 mm jack)

It is for Smart-V-Link for Windows for comprehensive vascular testing and data storage.

- (1) Connect a computer with designated communication cable (option).
- (2) Press the Power Button to turn the unit on.
- (3) Run Smart-V-Link (option) on your computer.

Note: For software operation, refer to the software operating manual.

6-5. Symbol list

Symbols	Description	Symbols	Description
	Type BF applied part		Back button
	Headset		Shuttle button
	Power ON / OFF		Manufacturer
	Serial port		Authorized representative in Europe
	Volume control		

6-6. Contents in package

- Main unit 1
- Probe 1
- Carrying case..... 1
- Ultrasonic gel (AQUAULTRA BASIC) .. 1
- Battery 1

7. Options

7-1. Probe selection

The frequency of diagnostic ultrasound is inversely proportional to depth of penetration. Use those probes depending on your applications.

Standard Doppler probe:

Standard:



- 2MHz: BT2M20S8C
- 4MHz: BT4M05S8C
- 5MHz: BT5M05S8C
- 8MHz: BT8M05S8C
- 10MHz: BT10M5S8C

Flat:



- 2MHz: BF2M20S8A
- 8MHz: BF8M15S8A

Sterilizable probe: (Amplifier required)

Small pencil:



- 8MHz: VRP-08
- 10MHz: VRP-10
- 20MHz: VRP-20

Long:



- 8MHz: LRP-08
- 10MHz: LRP-10

Flat:



- 8MHz: FDP-08

Autoclavable:



- 8MHz: ACP-08

Curved pencil:



10MHz: CRP-10H*
20MHz: CRP-20H*
20MHz: CRP-20H1N*

Bayonet:



10MHz: NRP-10H*
20MHz: NRP-20H*

Flexible:



10MHz: NRP-10HF*
20MHz: NRP-20H1NF*

Single use:



10MHz: NDP-10H*
20MHz: NDP-20H*

Amplifier:



8MHz: BDP8MS8
10MHz: BDP10MS8
20MHz: BDP20MS8

PPG probe:



PG-21

Temperature Probe:



TP-02*

**: Except European Union Countries.*

7-2. Others

- Neck strap (Except European Union Countries)
- Smart-V-Link software with communication cable

7-3. Photoplethysmograph

With the PPG probe, PG-21, Bidop senses the reflection of light from the hemoglobin of the red blood cells in surface vessels by utilizing infrared light. Basically, "How to use photoplethysmograph" is described in this manual. For other matters such as Cautions, Technical information and Interpretations of test result, refer to the Operating Manual that comes with your PPG probe.

7-3-1. PPG (Photoplethysmography) Probe Assembly

Single-channel photoplethysmography (PPG) probe

Model PG-21

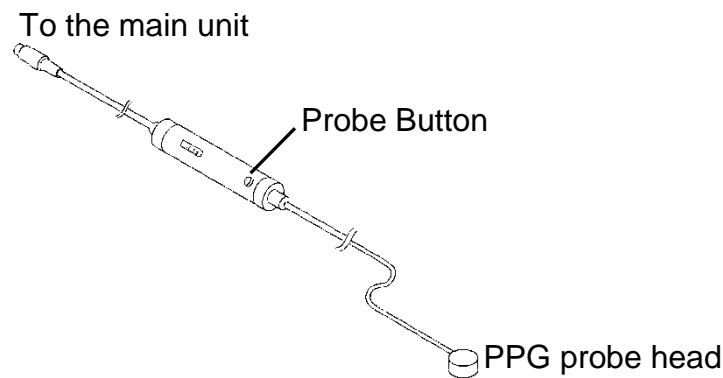

AC Coupling: Arterial pulse waveform studies, Toe pressure

DC Coupling: Venous reflux study

7-3-2. PPG - Arterial Pulse Waveform Studies

Purpose:

Arterial pulse waveform studies by photoplethysmography are performed to determine the presence or absence of pulsatile flow and to assess the state of perfusion in the tissue area immediately beneath the sensor site. When used with a suitable cuff and manometer, the method permits the measurement of systolic blood pressure in the fingers and toes.

Preparation:

(1) Connect the PPG probe to the unit and turn it on.

(2) Press Shuttle Button to display MENU and make sure MODE is set for AC mode. If it's been set for DC mode, press Shuttle on MODE to change to AC. Press BACK to get out of the MENU mode.

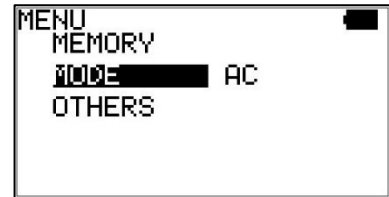

(3) Check that the face of the PPG sensor is free of stains. Clean it if necessary.

(4) Make certain that room temperature is comfortable and, especially, that the skin surface where the probe is to be mounted is warm. Cold constricts superficial blood vessels and thus jeopardizes the accuracy of PPG measurements.

Examination Procedure:

(1) Apply the sensor with the clear side against the skin surface, and fix it in place using Velcro straps, PPG clip (Option) or double-sided clear tape.

(2) The gain is automatically adjusted and the PPG waveform is shown on the LCD. High-pitched sounds following heartbeats can be heard from speaker and mute it with volume control if desired.

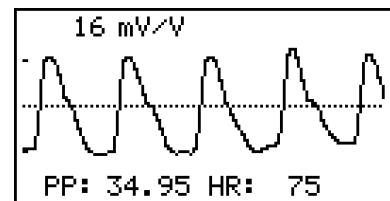

(3) When the waveform gets stable and rhythmic, press probe button to freeze the waveform.

(4) If you wish to store the data on the memory, see “§ 4-2-a. MEMORY - STORE”.



7-3-3. PPG - Venous Reflux Study

Purpose:

The venous reflux study is performed to assess valvular competence by measuring the amount of time required for venous refilling after calf veins have been emptied through exercise.

Preparation:

(1) Connect the PPG probe to the unit and turn it on.

(2) Press Shuttle Button to display MENU. Select MODE and press Shuttle to set for DC mode.

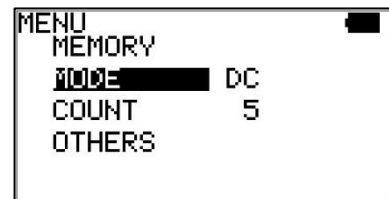

(3) COUNT represents number of foot exercise during study and if desired, press Shuttle on COUNT and turn it up and down to change the number.

Press BACK to get out of the COUNT sub menu.

(4) Check that the face of the PPG sensor is free of stains. Clean it if necessary.

(5) Make certain that room temperature is comfortable and that the skin surface of the lower limb is warm. Cold constricts superficial blood vessels and thus jeopardizes the accuracy of PPG measurements.

Examination Procedure:

(1) Have the patient sit on an examination table so that the feet are off the floor.

(2) Apply the sensor, with the clear side against the skin surface, to the medial malleolus over the posterior tibial vein. Fix the sensor in place with double-sided clear tape.

(3) Press probe button to begin the measurement process.

(4) Ask the patient to flex the foot specified number on COUNT following the foot animation and beep on Bidop. The exercise should be forceful, especially when lifting the foot upward.

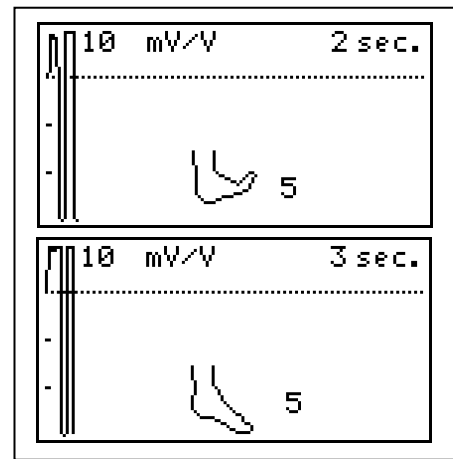

(5) After flexing, instruct the patient to relax the foot and avoid all movement.

(6) The test is completed when the waveform returns to the baseline and Bidop will automatically freeze the waveform and calculate recovery times.

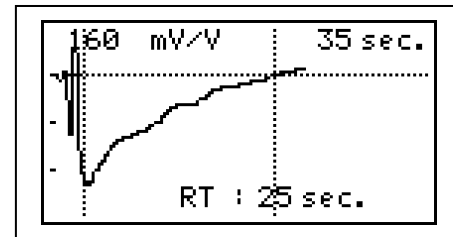

Note: "1/2" is the half recovery time for returning to 50% of refilling amplitude where middle vertical dotted line is shown.

(7) If you wish to store the data on the memory, see "§ 4-2-a. MEMORY - STORE".

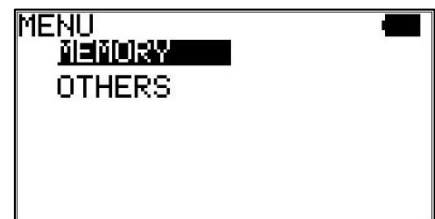

(8) Press the probe button to get out of the freeze mode.

7-3-4. Menu for PPG

Menu	Sub Menu	Selections	Reference in §4-2.
MEMORY	STORE	1 to 30, FREEZE	a. MEMORY - STORE
	READ	1 to 30, FREEZE	b. MEMORY - READ
	CLEAR	1 to 30, ALL	c. MEMORY - CLEAR
MODE		AC , DC (Measurement mode only)	7-3-6. MODE
COUNT		1 to 20 (DC mode only)	7-3-6. COUNT
OTHERS	LANGUAGE	ENGLISH , DEUTSCH, ITALIANO, ESPANOL, FRANCAIS, TURKCE, POLSKI	m. OTHERS - LANGUAGE
	FREEZE	MANUAL , AUTO	t. OTHERS-FREEZE
	BACKLIGHT	ON, OFF , 10 to 60 (10 sec. steps)	r. OTHERS - BACKLIGHT
	AUTO-OFF	ON , OFF	s. OTHERS - AUTO-OFF

Note1: STORE menu is available when on freeze mode only.

Note2: MODE is selectable when in Measurement mode.

Note3: COUNT is used for DC mode when in Measurement mode.

7-3-5. PPG Mode settings

MODE (AC / DC) (Only available in Measurement mode):

(1) Select MODE with Shuttle Button.

(2) Press it to change mode as follows:

AC: For arterial testing

DC: For venous reflux study



COUNT (Only available in DC - Measurement mode):

Set the number for foot exercise.

(1) Press Shuttle button on COUNT and turn it up and down to change the number.

(2) Press it to fix it.

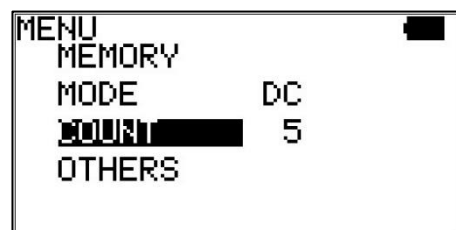

7-4. Foot Temperature (Except European Union Countries)

With optional temperature probe (TP-02), Bidop can detect foot temperature.

Model TP-02

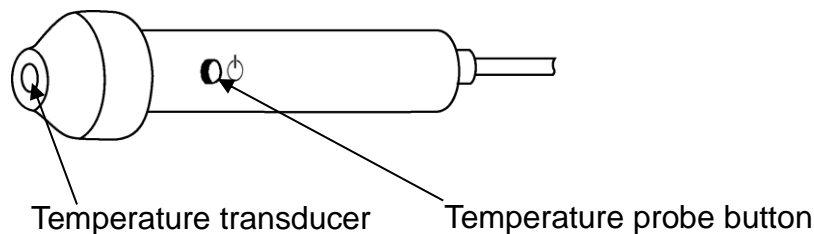

7-4-1. Foot temperature study

- (1) Connect the temperature probe to the unit and turn the unit on.

Foot temperature screen will be shown as shown in the right.

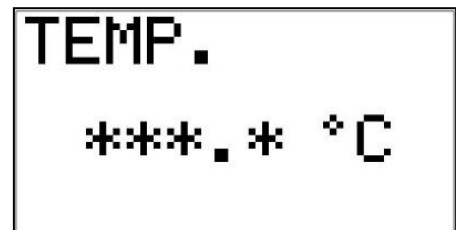

- (2) Select the temperature unit on UNIT menu for either Celsius (°C) or Fahrenheit (°F).

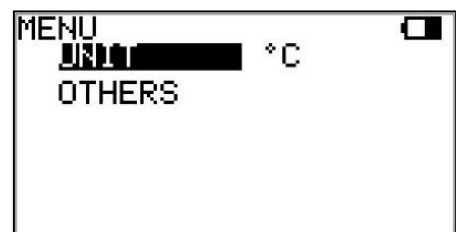

- (3) Get the probe tip close to the measurement site less than 4 cm as shown in the right.

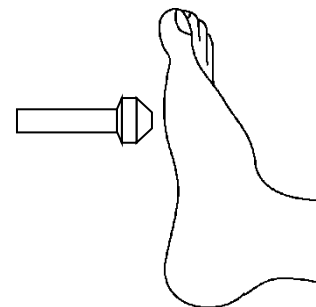

- (4) Press the probe button to measure and show the temperature on the LCD.



Note: Comprehensive foot temp. study can be organized with Smart-V-Link for Windows, optional.

7-5-2. Menu for Foot temperature

Menu	Sub-menu	Selections	Reference in §.4-2
UNIT		°C, °F	7-4-1-(2)
OTHERS	LANGUAGE	ENGLISH , DEUTSCH, ITALIANO, ESPANOL, FRANCAIS, TURKCE, POLSKI	m. OTHERS - LANGUAGE
	BACKLIGHT	ON, OFF , 10 to 60 (10 sec. steps)	r. OTHERS - BACKLIGHT
	AUTO-OFF	ON , OFF	s. OTHERS - AUTO-OFF

Specifications:

Temperature measuring method: non-contact

Accuracy: $\pm 0.5^{\circ}\text{C}$ (measurement range 10 to 40 °C),
when operating temperature is 0 to 40°C

Display Resolution: 0.1°C

FOV: 4:1 (object distance: measuring range)

Emissivity: 0.98

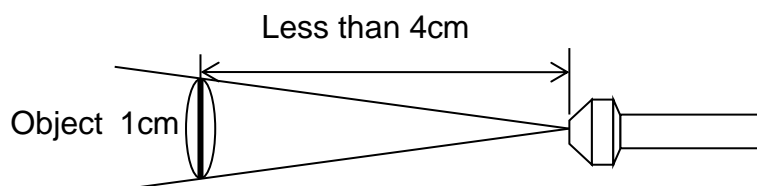

8. Technical information

8-1. Principles

Model ES-100V3 Bidop is designed to obtain various blood flow velocity through the ultrasound which is transmitted from probe to patient body and is reflected by the blood (hemocyte, etc.).

The unit amplifies the high frequency oscillation output and then supplies it to the transmitter transducer. It is converted to ultrasound by the transducer and the ultrasound is transmitted to external objects. The ultrasound moves straight through biophysical object, and is reflected by the moving object (blood flow etc.).

The reflected ultrasound is received by the receiving transducer and is converted into electric signals again.

The converted signals are amplified and then detected. After removing unnecessary noise from the signals and improving S/N ratio at the filter circuit, the Doppler shift signals are amplified and are converted to audible sounds through a speaker or a headset.

Simultaneously, the Doppler shift signals are applied to the CPU and converted to blood flow velocity waveform signals which can be displayed.

8-2. Block diagram

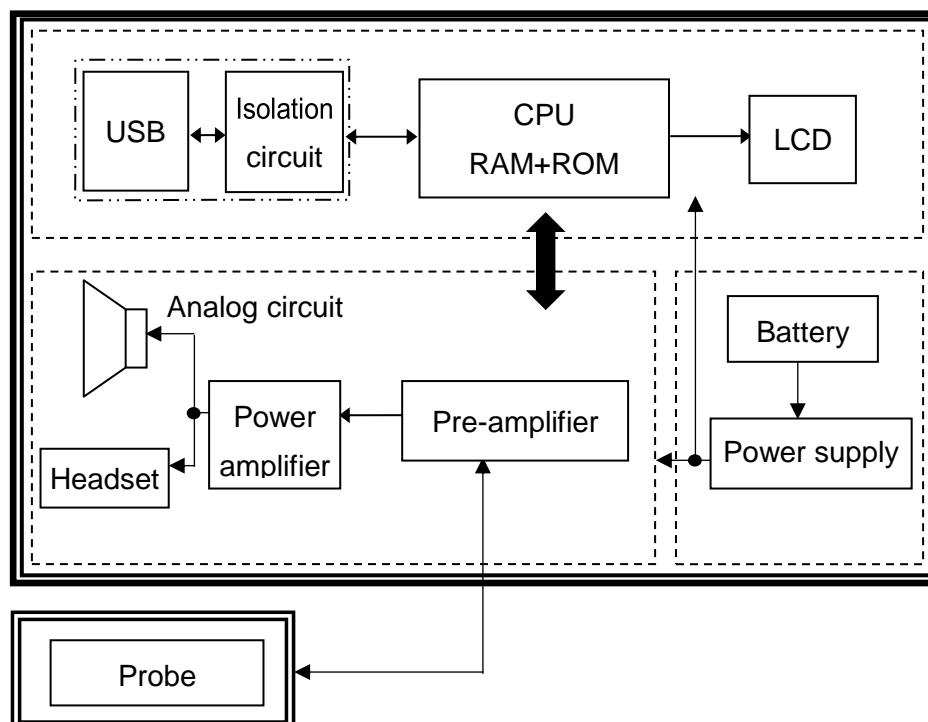

8-3. Specifications

Probes:	Model	Freq.	Ispta* (in situ) [mW/cm ²]
	BT2M20S8C	2 MHz	80 or less
	BT4M05S8C	4 MHz	390 or less
	BT5M05S8C	5 MHz	390 or less
	BT8M05S8C	8 MHz	390 or less
	BT10M5S8C	10 MHz	390 or less
	<i>* Ispta: Special Peak-Temporal Average Intensity.</i>		
Battery:	DC 9 volts, Alkaline square type battery		
Battery life:	Approx. 2.5 hours (When using with alkaline battery and backlight off.)		
Automatic shut-off	No signal: 2 min. Freeze: 5 min. Others: 15 min. (only FHR WAVE mode: 35 min.)		
Frequency range:	80 / 200 Hz to 5 kHz		
Mode settings:	Memory, Waveform, Direction, Time scale, Others		
Waveform memory:	30 waveforms		
LCD display:	128 x 64 dots, STN LCD with backlight Bi-directional waveform (normal & slow mode) Numerical data (Systolic, diastolic & mean velocities, RP, PI, SD, HR) Heart rate: 30 to 300 BPM, accuracy of $\pm 3\%$ Low battery indicator		
Velocity accuracy:	$\pm 10\%$ or less comparing with internal phantom testing.		
Speaker output:	300 mW or more		
External outputs:	Headset, serial port (USB)		
Electrical safety:	Conform to IEC60601-1 Internally powered equipment Type BF applied part.		
Operating environment:	 10 to 37 °C 85% humidity or less with no condensation		

Storage and transport environment:

0 to 50 °C

85% humidity or less with no condensation

Dimensions: Main unit: 78 (W) x 141 (L) x 27 (H) mm
(Probe holder not included)

Probe: 20 (Diam.) x 105 (L) mm

Weight: 220 grams (including battery, probe not included)

Manufacturing date: The first 2 digits and following 2 digits of the serial number represent the year and month of manufacturing, respectively.
The serial number is located inside of the battery compartment and it consists of 4 to 8 digits and may start with "Serial number" or "SN".

Examples:

03020001: Feb/2003

0401: Jan/2004

* Specifications subject to change

8-4. Safety standards

The unit confirms to the following standards: IEC60601-1

(1) Protection class against electric shock : Internally powered equipment
Protection grade against electric shock : Type BF applied part

(2) Guidance and manufacturer's declaration - electromagnetic emissions and immunity: IEC60601-1-2:2014(4th Edition)

Guidance and manufacturer's declaration – electromagnetic emissions		
The ES-100V3 is intended for use in the electromagnetic environment specified below. The customer or the user of the ES-100V3 should assume that it is used in such an environment.		
Emissions test	compliance	Electromagnetic environment - guidance
RF emissions CISPR 11	Group 1	The ES-100V3 use RF energy only for its internal function. Therefore, its RF emissions are very low and are not likely to cause any interference in nearby electronic equipment.
RF emissions CISPR 11	Class B	
Harmonic emissions IEC61000-3-2	Not applicable	The ES-100V3 is suitable for use in all establishments other than domestic and those directly connected to the public low-voltage power supply network that supplies buildings used for domestic purposes.

Voltage fluctuations/ flicker emissions IEC61000-3-3	Not applicable	
--	----------------	--

Guidance and manufacturer's declaration – electromagnetic immunity			
The ES-100V3 is intended for use in the electromagnetic environment specified below. The customer or the user of the ES-100V3 should assure that it is used in such an environment.			
Immunity test	IEC60601 test level	Compliance level	Electromagnetic environment - guidance
Electrostatic discharge(ESD) IEC61000-4-2	±8kV contact ±2kV, ±4kV, ±8kV, ±15kV air	±8kV contact ±2kV, ±4kV, ±8kV, ±15kV air	Floors should be wood, concrete or ceramic tile. If floors are converted with synthetic material, the relative humidity should be at least 30 %.
Electrical fast transient/burst IEC61000-4-4	±2kV for power supply lines(100KHz) ±1kV for input/output lines	Not applicable	
Surge IEC61000-4-5	±1kV differential mode ±2kV common mode	Not applicable	
Voltage dips, short interruptions and voltage variations on power supply input lines IEC61000-4-11	Dip to 0% for 1 cycles @ 0°phase angle Dip to 70% for 25/30 cycles @ 0°phase angle Dropout to 0% for 0.5cycle @ 0°, 45°, 90°, 135°, 180°, 225°, 270°&315° Interrupts 100% for 250/300 cycles	Not applicable	
Power frequency (50Hz) magnetic field IEC61000-4-8	30 A/m	30 A/m	Power frequency magnetic fields should be at levels characteristic of a typical location in a typical commercial or hospital environment.
NOTE U_T is the a.c. mains voltage prior to application of the test level.			

Guidance and manufacturer's declaration – electromagnetic immunity			
The ES-100V3 is intended for use in the electromagnetic environment specified below. The customer or the user of the ES-100V3 should assure that it is used in such an environment.			
Immunity test	IEC60601 test level	Compliance level	Electromagnetic environment - guidance
			Portable and mobile RF communications equipment should be used no closer to any part of the ES-100V3, including cables, than the recommended separation distance calculated from the equation applicable to the frequency of the transmitter. Recommended separation distance $d = 1,2\sqrt{P}$

Conducted RF IEC61000-4-6	3Vrms 150kHz to 80MHz, 1kHz 80%AM Modulation 6Vrms in ISM bands(I/O cables< 3m excluded) Patient coupled ports tested with current clamp	3Vrms 150kHz to 80MHz, 1kHz 80%AM Modulation 6Vrms in ISM bands(I/O cables< 3m excluded) Patient coupled ports tested with current clamp	$d = 1,2\sqrt{P}$ 80 to 800MHz $d = 2,3\sqrt{P}$ 800MHz to 2,5GHz where P is the maximum output power rating of the transmitter in watts (W) according to the transmitter manufacturer and d is the recommended separation distance in meters (m). Field strength from fixed RF transmitters, as determined by an electromagnetic site survey, ^a should be less than the compliance level in each frequency range. ^b Interference may occur in the vicinity of the equipment marked with the following symbol: 
Radiated RF IEC61000-4-3	3V/m, 80Mhz to 2,7GHz, 1kHz 80%AM modulation Table-9 (IEC60601-1-2:2014)	3V/m, 80Mhz to 2,7GHz, 1kHz 80%AM modulation Table-9 (IEC60601-1- 2:2014)	

NOTE 1 At 80 MHz and 800 MHz, the separation distance for the higher frequency range applies.
 NOTE 2 These guidelines may not apply in all situations. Electromagnetic propagation is affected by absorption and reflection from structures, objects and people.

- a Field strengths from fixed transmitters, such as base stations for radio (cellular/cordless) telephones and land mobile radios, amateur radio, AM and FM radio broadcast and TV broadcast cannot be predicted theoretically with accuracy. To assess the electromagnetic environment due to fixed RF transmitters, an electromagnetic site survey should be considered. If the measured field strength in the location in which the ES-100V3 is used exceeds the applicable RF compliance level above, the ES-100V3 should be observed to verify normal operation. If abnormal performance is observed, additional measures may be necessary, such as reorienting or relocating the ES-100V3.
- b Over the frequency range 150 kHz to 80 MHz, field strengths should be less than 3 V/m.

For European Union Countries:

EC	REP
----	-----

 European Authorized Representative

ICHIYAMA GmbH

Benderstraße 130, 40625 Düsseldorf, Germany

Tel: 0211-298538 Fax: 0211-299257



Hadeco



Manufactured by

Hadeco, Inc.

2-7-11 Arima, Miyamae-ku,
Kawasaki, Kanagawa
216-0003 Japan



May, 2018
Printed in Japan
080-00156-3.1